

RAIN HARVESTING

by Blue Mountain Co

Maelstrom® Original w/ Plastic Cage



Installation and Specification Guide

PRODUCT DETAILS

The Maelstrom® Filter's advanced design combines super-fine filtration and super-high water catchment efficiency to give you cleaner rainwater and more of it.

The unique U-shaped, twin stage filter keeps even the tiniest debris out of your tank while allowing massive volumes of water to flow through. The Maelstrom® range are the ultimate solutions for pre-tank filtration.

Code	Size	Country
RHML01	100mm	Global

Installation

WHAT'S IN THE BOX?

- Maelstrom® filter
- 3 flexible couplings
(two on Maelstrom® and one in box)

TOOLS/MATERIALS YOU MAY REQUIRE

- Screwdriver
- 6 screws for mounting to your tank
- Utility knife
- Marker pen
- Tape measure
- Brackets (wall mount or in-tank mount)
- Drill and Hole saw (pit mount or in-tank mount)
- 600mm/24" stormwater pit (pitmount)

HOW IT WORKS

1 - Rainwater enters the Maelstrom® through either of the horizontal-facing couplings.

2 - The rainwater then enters the Primary Filter (J). The unique curved filter slows the velocity of the water by changing the direction of it's flow.

3 - Surrounding the Primary Filter is a Secondary Filter (C), comprising of a nylon mesh bag which filters fine particulates larger than 180 micron. This filter assembly is easily removable and will require periodic maintenance.

4 - The filtered rainwater then continues to move through the Maelstrom® to the Filtered Water Outlet (F) and into the rainwater tank or pipe (if attached).

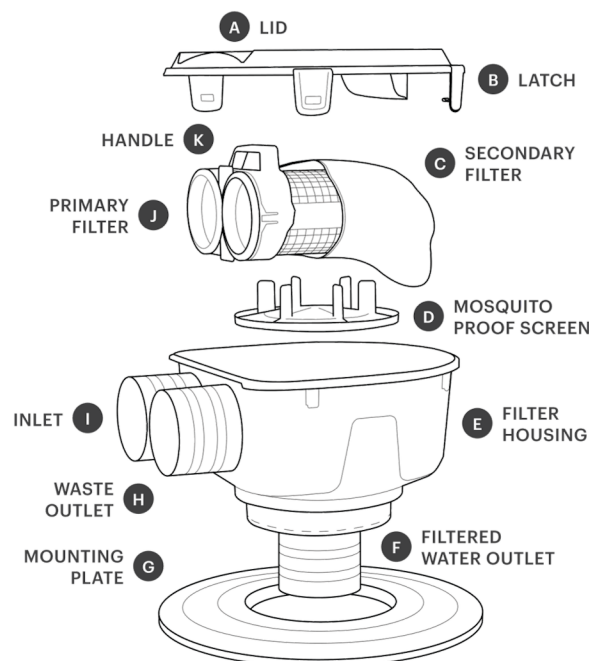
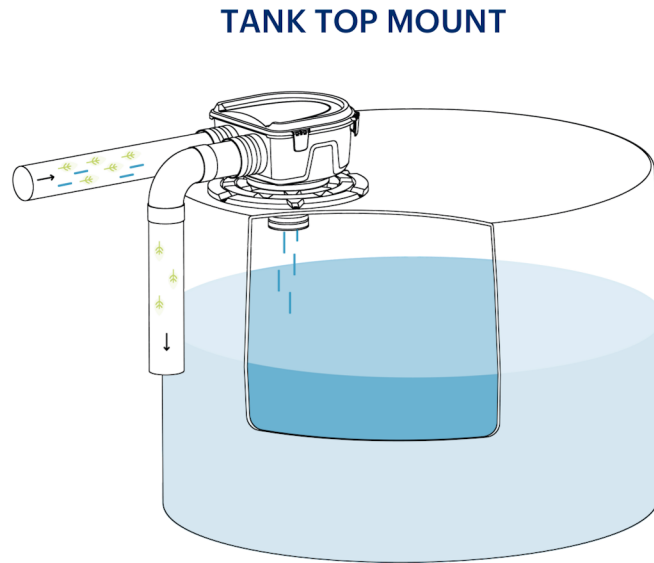

Figure 1

Suggested Installation Orientations



1 - Determine which port on your Maelstrom®'s symmetric U-bend you want to use for your water inlet and which port you want to use for your waste outlet. The filter works equally effectively in either direction, so assign each port depending on what's most convenient for your chosen installation point.

2 - Remove the existing tank screen from the opening of your rainwater tank by unscrewing and pulling it out and off the tank.

3 - Snap your Maelstrom® out of the mounting plate.

4 - Turn your Maelstrom®'s mounting plate upside down and, using your removed tank screen as a guide, trim to the nearest size by cutting in the channel as indicated. Ensure that once cut, the screw points on the mounting plate will still allow you to screw through the mounting plate into the top of the tank to provide a mosquito - proof seal.

5 - Centre the mounting plate over your tank inlets and screw it to your tank top.

6 - Remove the 100mm flexible coupling from the filtered water outlet (F), or you may wish to cut away the filtered water outlet from your Maelstrom® in the cut channel provided to expand the outlet size and allow more water to enter your tank than the standard 100mm outlet. This is recommended if your rain harvesting system is designed to harvest 100% of your roof catchment area or if you're in an area that experiences high peak flows during rain events.

7 - Snap your Maelstrom® in place through the opening in the mounting plate.

8 - Loosen the hose clamp on your chosen water inlet port. Measure and cut your inlet pipe and connect it so it fits within your chosen inlet port, then tighten the hose clamp around it.

9 - Loosen the hose clamp on your chosen waste outlet port. Where practical, we recommend plumbing the overflow outlet so that it directs excess water and debris to stormwater. Alternatively, you can cap your waste outlet with a vented flap valve.

10 - Whichever outlet option you choose, measure and cut your outlet pipe, insert it in your chosen outlet port, then tighten the hose clamp around it.

Figure 2

Suggested Installation Orientations

WALL MOUNT

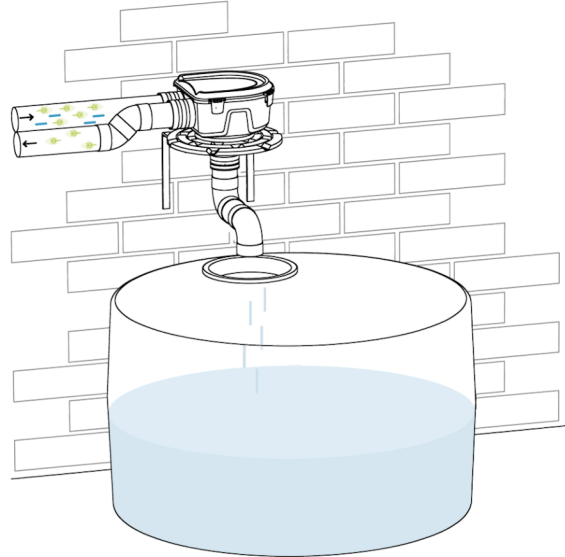

- 1 - Determine which port on your Maelstrom®'s symmetric U-bend you want to use for your water inlet and which port you want to use for your waste outlet. The filter works equally effectively in either direction, so assign each port depending on what's most convenient for your chosen installation point.
- 2 - Select appropriate brackets that can support your Maelstrom®'s mounting plate.
- 3 - Install the brackets on your wall so that they're positioned to sit 102mm (4") below your pipework and at least 260mm (10.2") apart so there's enough clearance for your Maelstrom®'s filtered water outlet.
- 4 - Snap your Maelstrom® out of the mounting plate.
- 5 - Screw the mounting plate to the brackets, ensuring it is centred.
- 6 - Snap your Maelstrom® in place through the opening in the mounting plate.
- 7 - Loosen the hose clamp on your chosen water inlet port. Measure and cut your inlet pipe as required and connect it so it fits within your Maelstrom®'s inlet port, then tighten the hose clamp around it.
- 8 - Loosen the hose clamp on your chosen waste outlet port. Where practical, we recommend plumbing the overflow outlet so that it directs excess water and debris to stormwater. Alternatively, you can cap your waste outlet with a vented flap valve.
- 9 - Whichever outlet option you choose, measure and cut your outlet pipe, insert it in your chosen outlet port, then tighten the hose clamp around it.
- 10 - Loosen the hose clamp on the filtered water outlet. Measure and cut an additional length of pipe to connect your filtered water outlet to your rainwater tank. Insert it inside the filtered water outlet and tighten the hose clamp around it.
- 11 - For best results, we recommend plumbing the other end of this pipe directly into your rainwater tank.

Figure 3

Suggested Installation Orientations

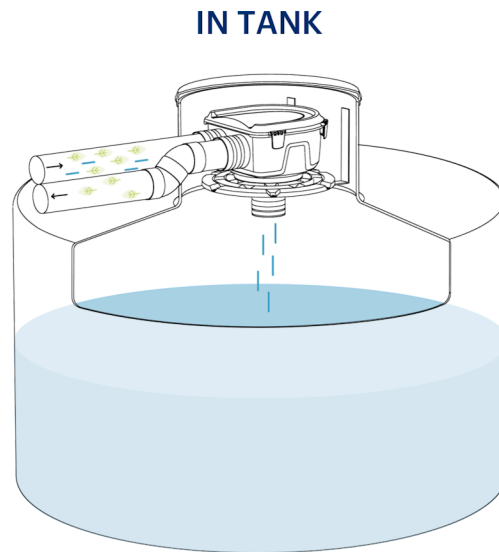

1 - Check that your assembled Maelstrom® (including flexible couplings and mounting plate) will fit within your tank riser. There must be enough space to allow the clips on the lid to open and for the inlet and outlet pipes to be connected to your Maelstrom®.

2 - Identify the location of any existing inlets through the riser and use this to determine the height at which your Maelstrom® will be positioned. The filter works equally effectively in either direction, so depending on what's most convenient for your chosen installation point, you can assign either port on your Maelstrom®'s symmetric U-bend as the water inlet or waste outlet.

3 - Select appropriate brackets that will support your Maelstrom® and install them inside the riser at least 260mm (10.2") apart so there's enough clearance for your Maelstrom®'s outlet.

4 - Mark where the outlet port will be located on the tank riser and use a hole saw to create the hole.

5 - Snap your Maelstrom® out of the mounting plate.

6 - Screw the mounting plate to the brackets, ensuring it is centred.

7 - Remove the 100mm flexible coupling from the filtered water outlet (F), or you may wish to cut away the filtered water outlet from your Maelstrom® in the cut channel provided to expand the outlet size and allow more water to enter your tank than the standard 100mm outlet. This is recommended if your rain harvesting system is designed to harvest 100% of your roof catchment area or if you're in an area that experiences high peak flows during rain events.

8 - Snap your Maelstrom® in place through the opening in the mounting plate.

9 - Loosen the hose clamp on your chosen water inlet port. Measure and cut your inlet pipe, insert it inside the tank riser and connect it so it fits within your chosen inlet port, then tighten the hose clamp around it.

10 - Loosen the hose clamp on your chosen waste outlet port. Where practical, we recommend plumbing the overflow outlet so that it directs excess water and debris to stormwater. Alternatively, you can cap your waste outlet with a vented flap valve.

11 - Whichever outlet option you choose, measure and cut your outlet pipe, insert it in the tank riser and your chosen outlet port, then tighten the hose clamp around it.

Figure 4

Suggested Installation Orientations

STORMWATER PIT MOUNT (600MM/24")

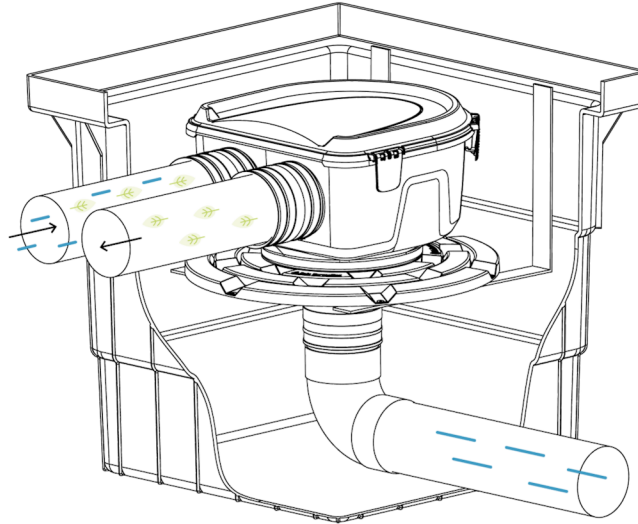

- 1 - If desired, your Maelstrom® can be installed below ground level in an appropriately sized stormwater pit.
- 2 - Determine the position of where your filtered water pipe will exit the pit and mark this position. The pipe can exit on either of the four sides or through the base. If exiting through the side wall you may wish to use a 90 degree bend to directly connect your pipe to the Maelstrom®s coupling.
- 3 - Determine the position your inlet and waste pipes will penetrate the sides of the pit wall and mark.
- 4 - Mark the position of the support rod holes. Support rods should be approx. 108mm (4.25") below the bottom of the inlet/waste pipes and approx. 300mm (11.8") apart to allow adequate support of the mounting plate.
- 5 - Drill out all penetration holes as required and deburr.
- 6 - Install and tighten threaded rod and appropriate nuts and washers to both inside and outside of pit wall for both supports. It is recommended to use stainless steel or galvanised components.
- 7 - Position the pit in place and install the filtered water pipe allowing for the required length to enter the coupling. Seal around the pipe and pit wall using appropriate sealant.
- 8 - Lower the Maelstrom® in place ensuring the coupling is positioned over the filtered water pipe and tighten the hose clamps.
- 9 - Install the inlet and waste pipes through the pit wall and into the Maelstrom®s coupling. Tighten the hose clamps and seal around the pipes and pit wall using appropriate sealant.
- 10 - It is recommended to install the pit with an appropriate lid to prevent water ingress.

OVERFLOW OPTIONS

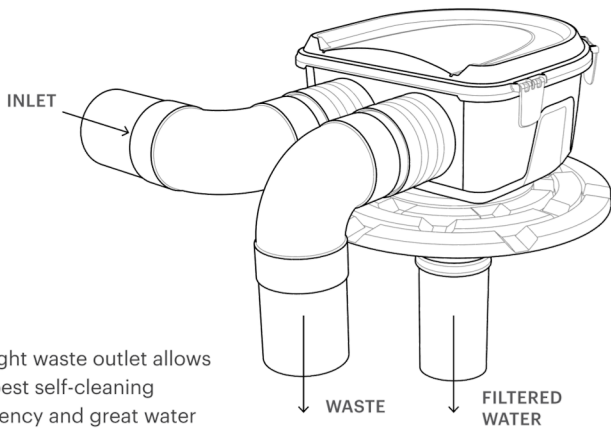

Straight waste outlet allows the best self-cleaning efficiency and great water catchment.

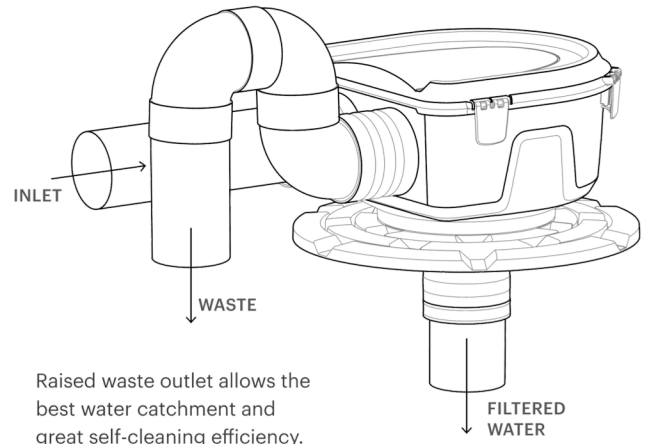

Raised waste outlet allows the best water catchment and great self-cleaning efficiency.

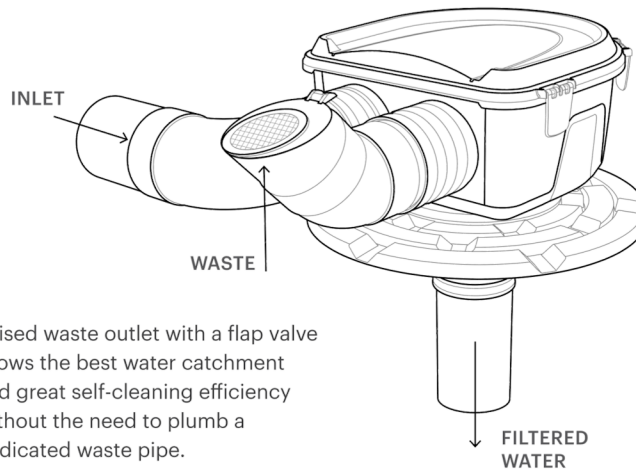

Raised waste outlet with a flap valve allows the best water catchment and great self-cleaning efficiency without the need to plumb a dedicated waste pipe.

Product Specifications

Maelstrom® Original w/ Plastic Cage

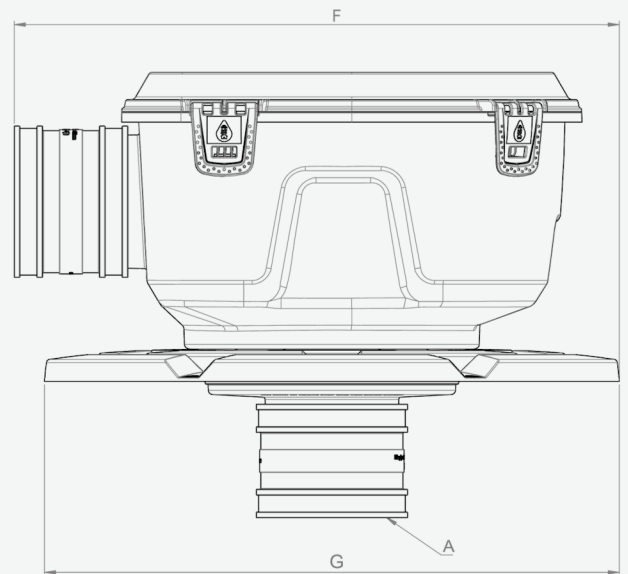
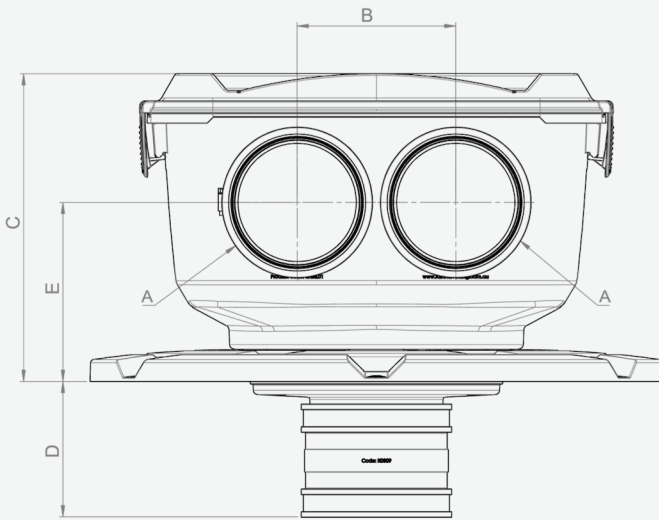

Country	Code	TANK HOLE SIZE	A	B	C	D	E	F	G
Global	RHML01	228-482	100 F with Flex Coupling	140	272	120	158	533	505 (Can be cut down)
		8.98"-18.98"	4" Flex Coupling	5.51"	10.71"	4.72"	6.22"	20.98"	19.88" (Can be cut down)

All dimensions are in mm unless otherwise stated.

Fitting guide:

F = Female / Socket Fitting

M = Male / Spigot Fitting (Pipe size)

IP = In-Pipe Fitting

Maintenance

For best performance, check and maintain your Maelstrom® on a regular basis. The required frequency of maintenance will depend on the environment in which your Maelstrom® is installed. High debris areas will require more regular maintenance than low debris areas.

To determine how frequently maintenance will be required in your location, we recommend inspecting the primary and secondary filter after the first rainfall event and planning your maintenance schedule based on this initial inspection.

To clean your Maelstrom®, unlatch and remove the lid.

Grasp the handle at the front of the filter and lift it upward to remove. Release the four handle clips, slide the handle off the primary filter and remove the secondary filter. Use a hose to wash out the secondary filter. If required, you can use a brush to remove any debris. Lift the mosquito proof screen out and brush or hose off any debris on either side of the screen.

Replace the mosquito proof screen, ensuring it sits securely in place. Replace the secondary filter and re-secure the handle. Return the filter to its position within the filter housing and clip it back in place, then replace the lid and secure it with the latches.



A common misconception about collecting rainwater is that all you need is a roof, a tank and some rain. This 'tanking' approach cannot always be relied on to deliver the volume – or quality – of water that you require. That is where we can help.

With some thought, your rain harvesting system can provide you with cleaner water and lots of it. Whether you're completely reliant on tank water or wanting to keep the garden green, our simple steps will help you achieve your goal.

The Rain Harvesting approach to rainwater collection involves using tested and proven products to make quality rainwater available for use in and around your property. You don't need much to get started and you will be surprised how easy it is to get the most out of your rainwater system.

[How can we help you?](#)

DISCLAIMER This product specification is not a complete guide to product usage. Further information is available from Rain Harvesting Pty Ltd and from the installation and Operating instructions. This specification sheet must be read in conjunction with the installation and Operating Instructions and all applicable statutory requirement. Product specifications may change without notice. © Rain Harvesting Pty Ltd

RAIN HARVESTING

by Blue Mountain Co

For more information or to find out
how we can help, just give us a call on

+61 7 3248 9600

Or visit our website at

rainharvesting.com